

HONDA

Power

Equipment

Owner's Manual
GENERATOR
EVD6010



**WARNING:**

The engine exhaust from this product contains chemicals known to the State of California to cause cancer, birth defects or other reproductive harm.

Thank you for purchasing a Honda generator. We want to help you get the best results from your new generator and to operate it safely. This manual contains the information on how to do that; please read it carefully.

This owner's manual describes the operation and maintenance of the EVD6010 Honda Generator. All information in this publication is based on the latest product information available at the time of printing. Honda Motor Co., Ltd. reserves the right to make changes at any time without notice and without incurring any obligation. No part of this publication may be reproduced without written permission.

This manual should be considered a permanent part of the generator and should remain with it if it is resold.

Safety Messages

Your safety and the safety of others is very important. We have provided important safety messages in this manual and on the generator. Please read these messages carefully.

A safety message alerts you to potential hazards that could hurt you or others. Each safety message is preceded by a safety alert symbol  and one of three words: DANGER, WARNING, or CAUTION.

These mean

 **DANGER** You **WILL** be **KILLED** or **SERIOUSLY HURT** if you don't follow instructions.

 **WARNING** You **CAN** be **KILLED** or **SERIOUSLY HURT** if you don't follow instructions.

 **CAUTION** You **CAN** be **HURT** if you don't follow instructions.

Each message tells you what the hazard is, what can happen, and what you can do to avoid or reduce injury.

Damage Prevention Messages

You will also see other important messages that are preceded by the word NOTICE.

This word means:

 **NOTICE** Your generator or other property could be damaged if you don't follow instructions.

The purpose of these messages is to help prevent damage to your generator, other property, or the environment.

CONTENTS

SAFETY	4
Safety Label Locations	4
Safety Information	5
GENERATOR INSTALLATION AND CONNECTIONS	7
Connection for a Vehicle	7
Connection to a Building's Electrical System	8
COMPONENT IDENTIFICATION	9
Control Box	10
PRE-OPERATION CHECK	11
Engine Oil	11
Fuel	12
Coolant	14
Exhaust System	16
STARTING AND STOPPING THE ENGINE	17
Starting the Engine	17
Stopping the Engine	17
GENERATOR USE	18
Appliance Operation	18
Engine Protection System	19
Low Oil Pressure Protection	19
Engine Overheating Protection	19
Circuit Breakers and Fuses	20
Circuit Breakers	20
Fuses	20
High Altitude Operation	21
MAINTENANCE	22
Tool Kit	22
Maintenance Schedule	23
Maintenance Record	24

Engine Oil Change	25
Air Cleaner Service	26
Spark Plug Service	27
Spark Arrester Service	29
STORAGE	30
TROUBLESHOOTING	31
WIRING DIAGRAMS	32
SPECIFICATIONS	34
WARRANTY SERVICE INFORMATION	35
INDEX	36

SAFETY

SAFETY LABEL LOCATION

These labels warn you of potential hazards that can cause serious injury. Read them carefully.

If a label comes off or becomes hard to read, contact your Honda Generator dealer for a replacement.

▲ WARNING

TO PREVENT FIRE HAZARD USE ONLY GENUINE HONDA AIR CLEANER ELEMENT (Part No. 17211-ZB5-003) FOR REPLACEMENT.

▲ WARNING

ELECTROCUTION OR PROPERTY DAMAGE CAN OCCUR. DO NOT CONNECT THIS GENERATOR TO ANY BUILDING'S ELECTRICAL SYSTEM UNLESS AN ISOLATION SWITCH HAS BEEN INSTALLED BY A LICENSED ELECTRICIAN. READ OWNER'S MANUAL CAREFULLY.

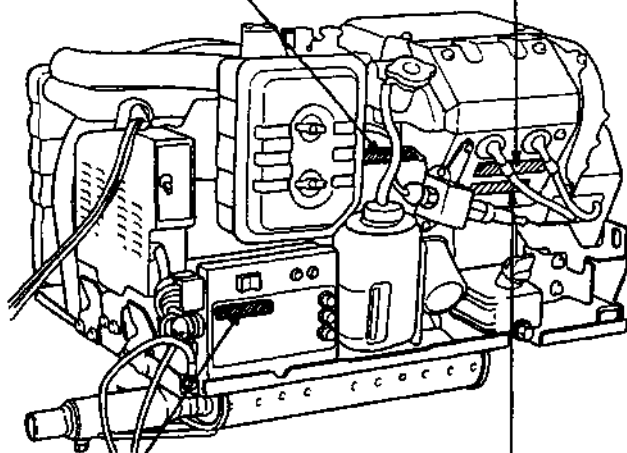

▲ WARNING

- THIS IS A POSITIVE TERMINAL ONLY.
- DO NOT ATTACH NEGATIVE LEAD.

▲ WARNING

TO PREVENT FIRE OR ACCIDENT HAZARD, THIS UNIT SHALL BE INSTALLED ONLY IN ACCORDANCE WITH THE MANUFACTURERS DETAILED INSTRUCTIONS.

SAFETY INFORMATION

Honda generators are designed to give safe and dependable service if operated according to instructions. Read and understand this owner's manual before operating your generator. You can help prevent accidents by being familiar with your generator's controls, and by observing safe operating procedures.

Operator Responsibility

- Know how to stop the generator quickly in case of emergency.
- Understand the use of all generator controls, output receptacles, and connections.
- Be sure that anyone who operates the generator receives proper instruction. Do not let children operate the generator without parental supervision.

Carbon Monoxide Hazards

- Exhaust contains poisonous carbon monoxide, which is a colorless and odorless gas that can cause loss of consciousness and may lead to death.
- Select a parking area that has enough ventilation for safe generator operation. If you run the generator in an area that is confined, or even partially enclosed, the air you breathe will contain a dangerous amount of exhaust gas.
- When parking, be careful that the exhaust is not directed into an area that you or your neighbors will use as working space. Avoid the exhaust area when the generator is running.
- Provide enough ventilation to keep exhaust gas from building up. Placing awnings or other objects in the exhaust area will restrict ventilation; this may cause exhaust gas to build up and enter working areas.

Electric Shock Hazards

- The generator produces enough electric power to cause a serious shock or electrocution if misused.
- Improper connection to a building's electrical system can cause electric power to backfeed through utility lines and may cause serious injury or death to utility workers or others. Consult the utility company or a qualified electrician before connecting the generator to a building's electrical system.

Fire and Burn Hazards

- **Improper generator installation or wiring connections can cause a fire. Installation should be done only by an authorized Honda generator dealer or other qualified generator installer.**
- **The exhaust system gets hot enough to ignite some materials. Make sure flammable materials such as vegetation, paper and wood products, and chemicals are kept clear of the exhaust system.**
- **Touching a hot engine or exhaust system can cause serious burns. Let the engine cool before performing maintenance.**
- **Gasoline is extremely flammable, and gasoline vapor can explode. Keep flames and sparks away, and do not smoke in the area.**
- **Coolant contains ethylene glycol, which is flammable. When ignited, it has an invisible flame that can cause severe burns. Use care when handling coolant.**

GENERATOR INSTALLATION AND CONNECTIONS

Connections for a Vehicle

⚠ WARNING Incorrect generator installation or connection can cause electrocution or fire. The generator must be installed and connected as described in the Honda EVD6010 Generator Installation Manual.

The EVD6010 generator should be installed by an authorized Honda generator dealer or other qualified generator installer. Installation must comply with the standards and codes of the following organizations:

U.S.A.: Occupational Safety and Health Administration (OSHA)
National Fire Protection Association (NFPA)
National Electric Code (NEC)

For protection against electrical shock, all 15 and 20 A, 120-volt receptacles connected to the generator must be protected by ground-fault circuit interrupters (GFCI's). All individual circuits must be provided with circuit breakers or fuses for protection against circuit overload.

If the vehicle is equipped to use an outside AC power source, the generator output wires must be completely isolated when the outside AC power source is connected.

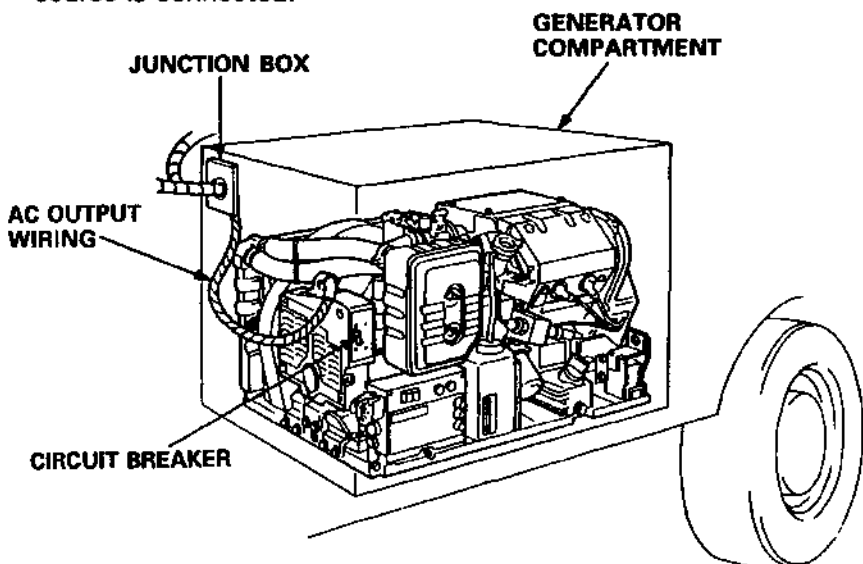

Connections to a Building's Electrical System

Although the Honda EVD6010 generator is designed for vehicle use, it can also supply power to a building's electrical system. If the generator will be used as an alternative to utility company power, an isolation switch must be installed to disconnect the utility lines from the building when the generator is connected. Installation must be performed by a qualified electrician and must comply with all applicable laws and electrical codes.

⚠ WARNING Improper connections to a building's electrical system can allow electric current from the generator to backfeed into utility lines and may cause serious injury or death to utility company workers or others who contact the lines. Consult the utility company or a qualified electrician.

Improper connections to a building's electrical system can allow electrical current from the utility company to backfeed into the generator. When utility power is restored, the generator may explode, burn, or cause fires in the building's electrical system.

In some areas, generators are required by law to be registered with local utility companies. Check local regulations for proper registration and use procedures.

COMPONENT IDENTIFICATION

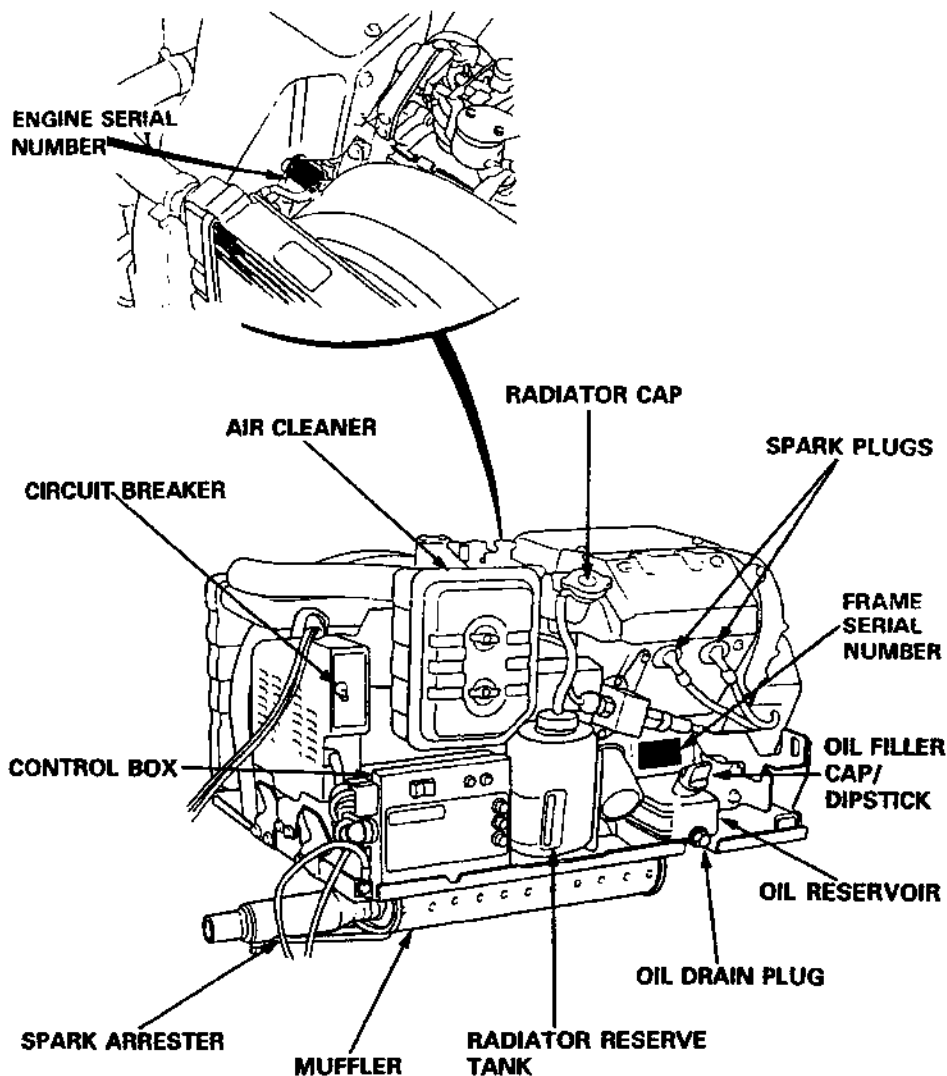

- Record the engine and frame serial numbers for your future reference. Refer to these serial numbers when ordering parts, and when making technical or warranty inquiries (see page 35)

Frame serial number: _____

Engine serial number: _____

CONTROL BOX

- Circuit breaker:** Switch ON for AC power. The breaker will automatically switch OFF if the circuit is more than 20% overloaded.
- Pilot lamp:** Lights when the engine is running and goes off when the engine is stopped.
- Overheating warning lamp:** Lights when the engine or coolant temperature exceeds the safe operating limit.
- Battery terminal:** Connect the battery positive (+) cable here.
- Ground terminal:** Connect the battery negative (-) cable here.
- Engine switch:** Starts and stops the generator engine.
- Fuse holders:** F1: 15 amp fuse; F2: 4 amp fuse; F3: 4 amp fuse.
- Remote control coupler:** The remote control panel coupler is connected here.

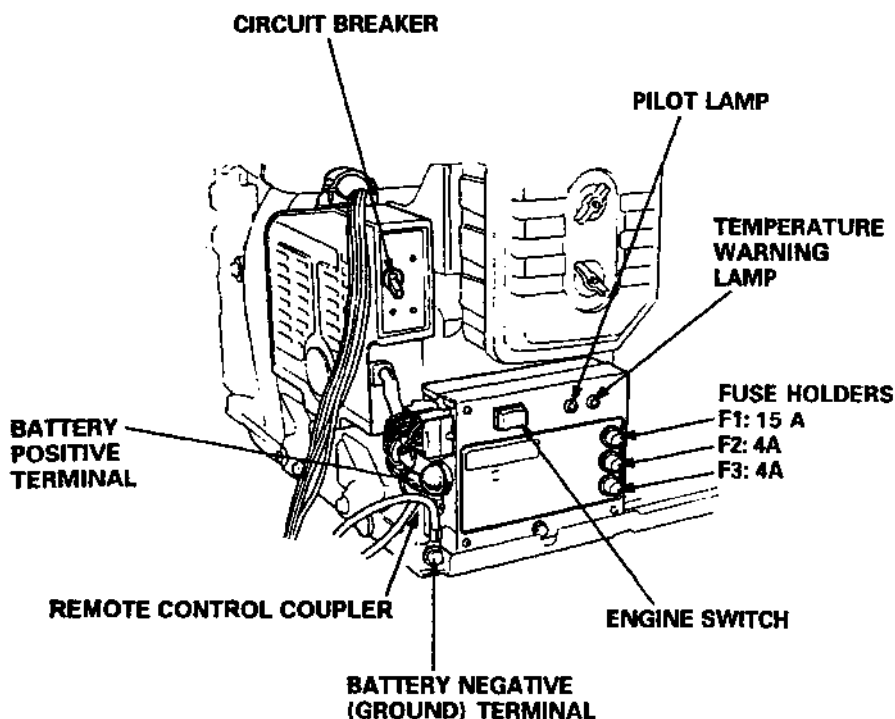

PRE-OPERATION CHECK

Engine oil

NOTICE Engine oil is a major factor affecting engine performance and service life. Nondetergent and 2-stroke engine oils will damage the engine and are not recommended.

Before you start the generator, check the engine oil level while parked on a level surface with the generator engine stopped.

Use Honda 4-stroke oil, or an equivalent high detergent, premium quality motor oil certified to meet or exceed U.S. automobile manufacturer's requirements for Service Classification SG, SF/CC, CD. Motor oils classified SG, SF/CC, CD will show this designation on the container.

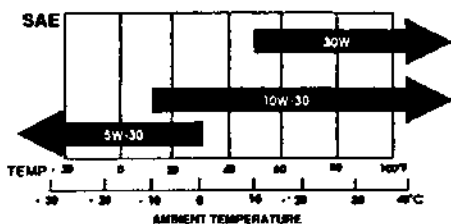

Oil capacity: 1.2 liters (1.27 US qt, 1.06 Imp qt)

SAE 10W-30 is recommended for general, all-temperature use. Other viscosities shown in the chart may be used when the average temperature in your area is within the indicated range.

The engine protection system will automatically stop the engine before the oil pressure falls below the safe limit. However, to avoid the inconvenience of an unexpected shutdown, you should inspect the oil level regularly.

1. Remove the oil filler cap and wipe the dipstick clean.
2. Insert the dipstick into the oil filler neck, but do not screw it in.
3. Check the oil level shown on the dipstick. If near the lower limit, fill to the upper limit with the recommended oil.

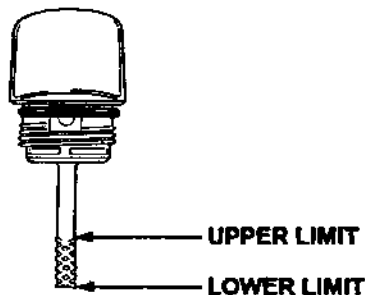
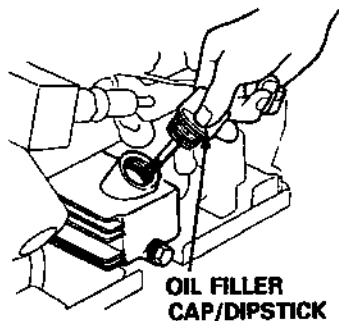

Fuel

Before starting the generator, check for fuel system leaks. Repair any fuel leaks before starting the generator.

⚠ WARNING Gasoline is extremely flammable, and gasoline vapor can explode, causing serious injury or death. Use extreme care when handling gasoline.

Keep flames and sparks away, and do not smoke in the area. Be sure the engine compartment is dry and clear of fuel vapor before starting the generator.

Fuel Recommendation

Use gasoline with a pump octane rating of 86 or higher.

We recommend unleaded gasoline because it produces fewer engine and spark plug deposits and extends exhaust system life.

Never use stale or contaminated gasoline or oil/gasoline mixture. Avoid getting dirt or water in the fuel tank.

Occasionally you may hear light "spark knock" or "pinging" (metallic rapping noise) while operating under heavy loads. This is no cause for concern.

If spark knock or pinging occurs at a steady engine speed, under normal load, change brands of gasoline. If spark knock or pinging persists, see an authorized Honda generator dealer.

NOTICE Running the engine with persistent spark knock or pinging can cause engine damage.

Running the engine with persistent spark knock or pinging is misuse, and the Distributor's Limited Warranty does not cover parts damaged by misuse.

Oxygenated Fuels

Some conventional gasolines are being blended with alcohol or an ether compound. These gasolines are collectively referred to as oxygenated fuels. To meet clean air standards, some areas of the United States and Canada use oxygenated fuels to help reduce emissions.

If you use an oxygenated fuel, be sure it is unleaded and meets the minimum octane rating requirement.

Before using an oxygenated fuel, try to confirm the fuel's contents. Some states/provinces require this information to be posted on the pump.

The following are the EPA-approved percentages of oxygenates:

ETHANOL — (ethyl or grain alcohol) 10% by volume

You may use gasoline containing up to 10% ethanol by volume. Gasoline containing ethanol may be marketed under the name "Gasohol".

MTBE — (Methyl Tertiary Butyl Ether) 15% by volume

You may use gasoline containing up to 15% MTBE by volume.

METHANOL — (methyl or wood alcohol) 5% by volume

You may use gasoline containing up to 5% methanol by volume, as long as it also contains cosolvents and corrosion inhibitors to protect the fuel system. Gasoline containing more than 5% methanol by volume may cause starting and/or performance problems. It may also damage metal, rubber, and plastic parts of your fuel system.

If you notice any undesirable operating symptoms, try another service station, or switch to another brand of gasoline.

Fuel system damage or performance problems resulting from the use of an oxygenated fuel containing more than the percentages of oxygenates mentioned above are not covered under warranty.

Coolant

⚠ WARNING

- Coolant contains ethylene glycol, which is flammable. When ignited, it has an invisible flame that can cause severe burns. Use care when handling coolant.
- Coolant may cause skin, eye, and mucous membrane irritation. Breathing high concentrations of mist or vapors may cause nausea. **SKIN or EYE CONTACT:** flush with water and go to a hospital. **IF SWALLOWED:** induce vomiting and call a physician. **KEEP OUT OF REACH OF CHILDREN.**

Check the coolant level in the reserve tank while parked on a level surface.

When the engine is at operating temperature, the coolant level should be between the MIN and MAX marks on the reserve tank. If the level is near the MIN mark, add coolant to bring the level up to the MAX mark.

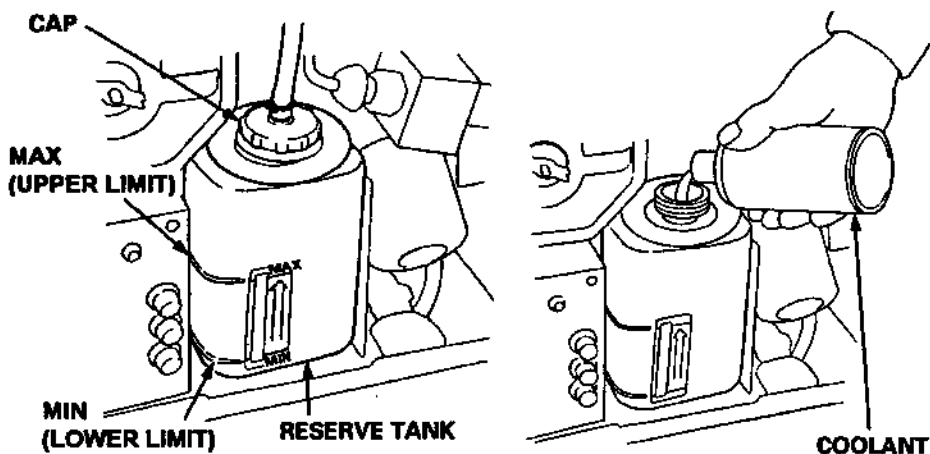

The engine protection system will automatically stop the engine if the coolant becomes excessively hot, which may occur if the coolant level is too low. To avoid the inconvenience of an unexpected shutdown, inspect the coolant level in the reserve tank regularly.

If there is no coolant in the reserve tank:

Make sure the engine is cool, then check the coolant system for leaks and have repairs made if needed. Add coolant to the radiator and reserve tank before starting the engine.

⚠ WARNING Hot coolant is under pressure. If you remove the radiator cap when the engine is hot, you may be scalded. Wait for the engine to cool.

1. When the engine is cool, relieve any remaining coolant pressure by turning the radiator cap counterclockwise until it reaches its stop; **DO NOT PRESS DOWN WHILE TURNING THE CAP.** After all pressure has been relieved, press the cap down and continue turning the cap to remove it.

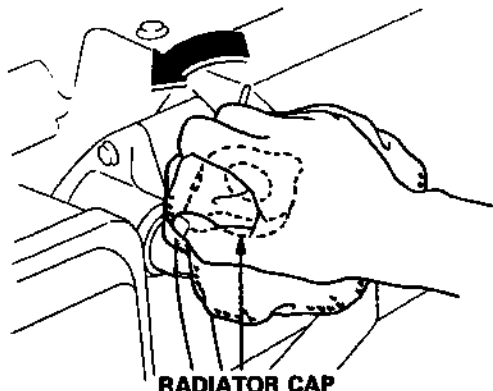

2. Fill the radiator with coolant, and reinstall the radiator cap. Tighten the cap securely.
3. Fill the reserve tank to the **MAX** mark with coolant.

Antifreeze/Coolant Recommendation

Use high quality ethylene glycol coolant that is specifically formulated for aluminum engines. Mix the coolant with low-mineral drinking water or distilled water.

A 50/50 mixture of ethylene glycol coolant and water is recommended for most temperatures, and it provides good corrosion protection. A higher concentration of coolant decreases cooling efficiency and is recommended if additional protection against freezing is needed. A concentration of less than 40% antifreeze will not provide enough corrosion protection.

NOTICE The wrong type of coolant, hard water, or salt water can cause corrosion damage in the engine.

Exhaust System

Check the exhaust system for any damage or deterioration. Look for dents, or leaks caused by rust.

⚠ WARNING Exhaust contains poisonous carbon monoxide, which is a colorless and odorless gas that can cause loss of consciousness and may lead to death. Repair any exhaust system leaks before starting the generator.

STARTING AND STOPPING THE ENGINE

Starting the Engine

1. Turn off all electrical loads (lights and appliances).
2. Push the engine switch to **START**, and hold the switch in that position until the engine starts and the green pilot light glows steadily.

If the engine does not start within 10 seconds, release the engine switch, and wait at least 30 seconds for the starter motor to cool before pushing the switch to **START** again.

NOTICE Using the electric starter for more than 10 seconds at a time can damage the starter motor.

If you experience difficulty starting the engine, turn the circuit breaker(s) **OFF** to be sure there is no electrical load on the generator, then push the engine switch to **START** again. Turn the circuit breaker(s) **ON** after the engine starts.

If the engine stops a few seconds after starting, this may indicate that the engine protection system has been activated (see page 19). Check the engine oil and coolant levels before attempting to restart the generator.

If the engine stops because it ran out of fuel, then, after refilling the vehicle's fuel tank, it may be necessary to operate the starter repeatedly, until fuel reaches the carburetor. (10 seconds **ON**, 30 seconds **OFF**)

Stopping the Engine

Push the engine switch to **STOP**, and release the switch. It is not necessary to hold the switch until the engine stops.

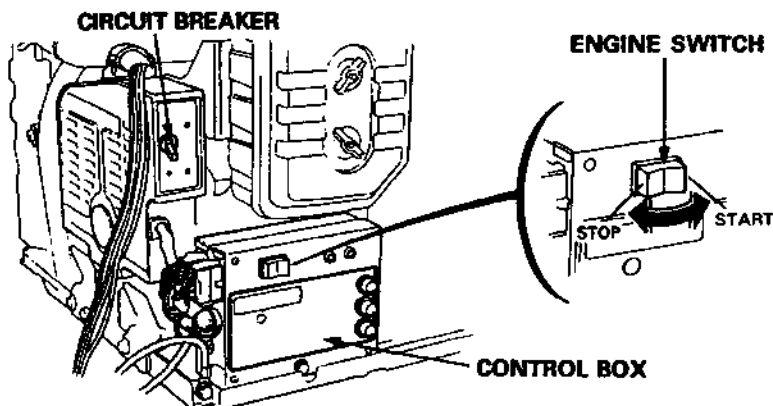

GENERATOR USE

Be sure your parking area has enough ventilation for safe generator operation. If you run the generator in an area that is confined, or even partially enclosed, the air you breathe will contain a dangerous amount of exhaust gas.

⚠ WARNING Exhaust contains poisonous carbon monoxide, which is a colorless and odorless gas that can cause loss of consciousness and may lead to death. Provide enough ventilation to keep exhaust gas from building up.

When parking, be careful that the exhaust is not directed into an area that you or others will use as working space. Avoid the exhaust area when the generator is running.

Placing awnings or similar structures in the exhaust area will restrict ventilation; this may cause exhaust gas to build up and enter working areas.

Obstructions, such as trees, rocks, dirt or snow embankments, or heavy brush can also restrict ventilation. Be sure the area near the exhaust pipe is clear of obstructions before starting the generator.

Be especially careful in snowy areas. Snow may build up near the exhaust pipe and trap exhaust gas, causing it to enter the working area.

Be sure that anyone who operates the generator receives proper instruction. Do not let children operate the generator without parental supervision.

Appliance Operation

To avoid overloading the generator, be sure the total power requirements of all connected appliances do not exceed maximum generator output.

Maximum power is: 6.0 kVA

Most appliance and power tool motors require more than their rated operating current for startup. To match appliance power needs to generator capability, allow a sufficient generator power reserve to accommodate motor startup requirements.

Be sure that all appliances are in good working order before connecting them to the generator. If an appliance begins to operate abnormally, becomes sluggish, or stops suddenly, turn off the appliance or the generator circuit breaker immediately. Disconnect the appliance, and determine whether the problem is due to appliance malfunction or generator overloading.

Engine Protection System

The engine protection system will automatically stop the engine to prevent damage from lack of lubrication or overheating.

Low Oil Pressure Protection

If there is a loss of oil pressure, which may indicate low oil level, the engine protection system will automatically stop the engine.

If this occurs, check the engine oil level, and add oil if the level is low (see page 11).

Engine Overheating Protection

If the engine or coolant becomes too hot, the engine protection system will automatically stop the engine, and the temperature warning lamp will light. The temperature warning lamp is located on the generator control box.

If this occurs, check the coolant level, and refill if the coolant level is low (see pages 14 & 15). If the cooling system leaks, or if the temperature warning lamp lights with the cooling system properly filled, take the generator to an authorized Honda generator dealer.

Allow an overheated engine to cool for 15 to 40 minutes before re-starting. If restarted while overheated, the engine protection system will immediately stop the engine again. The generator is ready for operation when the temperature warning lamp is no longer lit.

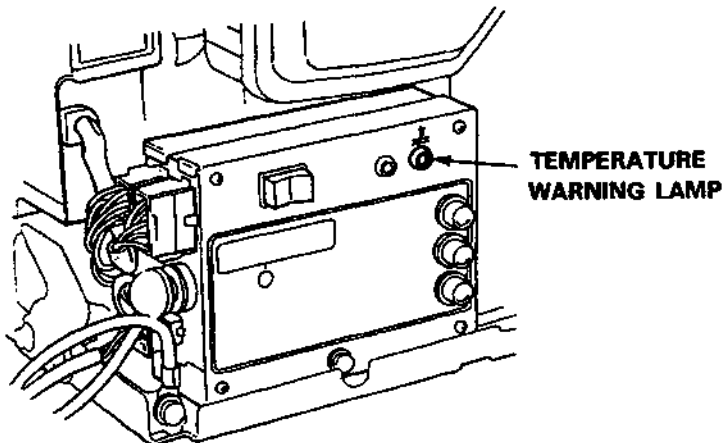

Circuit Breaker and Fuses

The generator's electrical system is protected by 3 fuses in the generator control unit and a circuit breaker for the AC output circuit.

Circuit Breaker

An overload will trip (switch off) the circuit breaker. If this happens, reduce the electrical load on the circuit. Wait a few minutes before resetting the circuit breaker.

Fuses

In the event of fuse failure, locate and repair the cause of the failure. To replace a fuse, unscrew the fuse holder, and install a replacement fuse of the specified rating. Then reinstall the fuse holder, and tighten it securely.

NOTICE Using fuses with ratings higher than specified can cause a fire or equipment damage.

CIRCUIT BREAKER

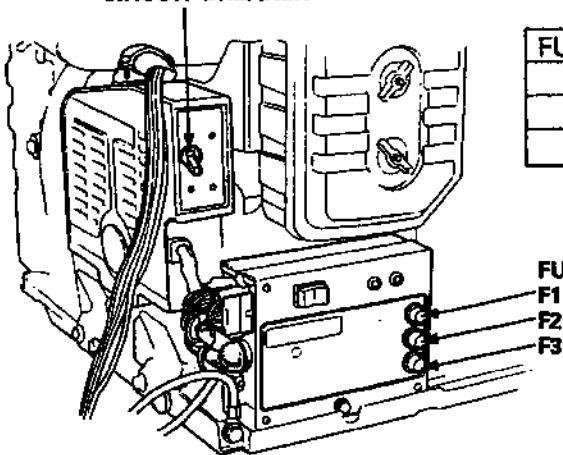

FUSE HOLDER	FUSE RATING
F1	15 A
F2	4 A
F3	4 A

FUSE HOLDERS

F1
F2
F3

If frequent fuse failure occurs, consult an authorized Honda generator dealer to determine the cause. Correct the problem before operating the generator again.

High Altitude Operation

At high altitude, the standard carburetor air-fuel mixture will be excessively rich. Performance will decrease, and fuel consumption will increase. A very rich mixture will also foul the spark plug, cause hard starting and contribute to air pollution.

High altitude performance can be improved by installing a smaller diameter main fuel jet in the carburetor and readjusting the pilot screw. If you always operate the engine at altitudes higher than 6,000 feet above sea level, have an authorized Honda generator dealer perform this carburetor modification.

Even with suitable carburetor jetting, engine horsepower will decrease approximately 3.5% for each 1,000 foot increase in altitude. The effect of altitude on horsepower will be greater than this if no carburetor modification is made.

NOTICE When the carburetor is modified for high altitude operation, the air-fuel mixture will be too lean for low altitude use. Operation at altitudes below 1,800 meters (6,000 feet), with high altitude carburetor modifications, may cause the engine to overheat and result in serious engine damage. For low altitude use, reinstall the standard main fuel jet, and readjust the pilot screw.

MAINTENANCE

Periodic maintenance and adjustment are necessary to keep the engine in good operating condition. Service and inspect according to the MAINTENANCE SCHEDULE.

⚠ WARNING Exhaust gas contains poisonous carbon monoxide. Shut off the engine before performing any maintenance. If the engine must be run, make sure the area is well ventilated.

NOTICE Use only genuine HONDA parts or their equivalent for maintenance or repair. Replacement parts which are not of equivalent quality may damage the generator.

To avoid serious burns, allow the engine to cool before performing maintenance.

Tool kit

The tools supplied are necessary for spark plug service. Always keep the tool kit, and the owner's manual, with the generator.

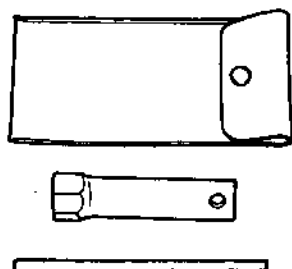

Maintenance Schedule

REGULAR SERVICE PERIOD		Each use	First 20 Hrs. (3)	Every 100 Hrs. (3)	Every 200 Hrs. (3)	Every 300 Hrs. (3)
Items	Perform at every indicated operating hour interval					
Exhaust system	Check	●				
Engine oil	Check level	●				
	Change		●		●	
Air filter	Clean			● (1)		
	Replace				●	
Radiator coolant	Check level	●				
	Change					● (2)
Spark plug	Clean—Readjust				●	
Spark arrester	Clean			●		
Valve clearance	Check—Readjust					● (2)
Oil filter	Change				● (2)	
Fuel filter	Change					● (2)
Fuel line	Check (Replace if necessary)					● (2)

- NOTES: (1) Service more frequently when the generator is used in dusty areas.
 (2) This service should be performed by an authorized Honda generator dealer, unless the owner has the proper tools and is mechanically proficient. See the Honda Shop Manual.
 (3) For professional commercial use, log hours of operation to determine proper maintenance intervals.

Maintenance Record

Use this chart to record the scheduled maintenance performed.

Interval Items Hours	Every 100 Hr.	Every 200 Hr.	Every 300 Hr.
	<ul style="list-style-type: none"> • Air filter cleaning • Spark arrester cleaning 	<ul style="list-style-type: none"> • Engine oil change • Oil filter change • Air filter replacement • Spark plug maintenance 	<ul style="list-style-type: none"> • Fuel filter replacement • Valve clearance adjustment • Radiator coolant change • Fuel line check
100 Hr.	○		
200 Hr.	○	○	
300 Hr.	○		○
400 Hr.	○	○	
500 Hr.	○		
600 Hr.	○	○	○
700 Hr.	○		
800 Hr.	○	○	
900 Hr.	○		○
1000 Hr.	○	○	
1100 Hr.	○		
1200 Hr.	○	○	○
1300 Hr.	○		
1400 Hr.	○	○	
1500 Hr.	○		○
1600 Hr.	○	○	
1700 Hr.	○		
1800 Hr.	○	○	○
1900 Hr.	○		
2000 Hr.	○	○	
2100 Hr.	○		○
2200 Hr.	○	○	
2300 hr.	○		
2400 Hr.	○	○	○
2500 Hr.	○		

Engine oil change

Drain the oil while the engine is warm to assure rapid and complete draining.

1. Remove the filter cap/dipstick and the drain plug, and allow the oil to drain into a suitable container.
2. Check that the drain plug washer is in good condition (replace if necessary), then install the drain plug and tighten it securely.
3. Remove the filler cap/dipstick, and refill with the recommended oil (see page 11) to the upper level on the dipstick. Install the filler cap/dipstick.
4. Run the engine for a few minutes, then recheck the oil level. Add oil if necessary.

Oil capacity: 1.2 l (1.27 US qt, 1.06 Imp qt)

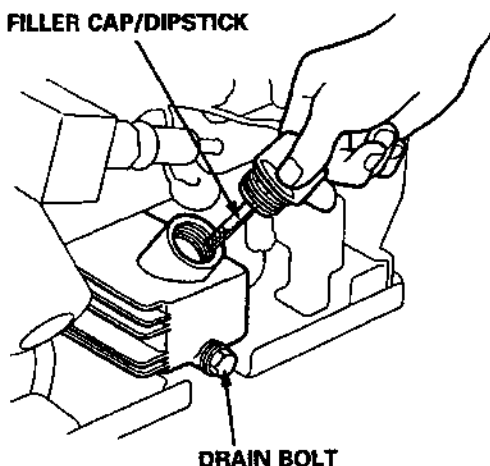

CAUTION Used motor oil may cause skin cancer if repeatedly left in contact with the skin for prolonged periods. Although this is unlikely unless you handle used oil on a daily basis, it is still advisable to thoroughly wash your hands with soap and water as soon as possible after handling used oil.

Please dispose of used motor oil in a manner that is compatible with the environment. We suggest you take it in a sealed container to your local service station or recycling center for reclamation. Do not throw it in the trash or pour it on the ground.

Air Cleaner Service

A dirty air filter will restrict air flow to the carburetor, reducing engine performance. If the generator is operated in very dusty areas, clean the air filter more frequently than specified in the MAINTENANCE SCHEDULE.

⚠ WARNING Using gasoline or flammable solvent to clean the filter element can cause a fire or explosion. Use only soapy water or nonflammable solvent.

NOTICE Never run the generator without the air filter. Rapid engine wear will result.

1. Remove the wing nuts and air cleaner cover. Remove the elements and separate them. Carefully check both elements for holes or tears, and replace if damage.
2. Foam element: Clean in warm soapy water, rinse, and allow to dry thoroughly. Or clean in nonflammable solvent and allow to dry. Dip the element in clean engine oil and squeeze out all excess oil. The engine will smoke during initial running if too much oil is left in the foam.
3. Paper element: Tap the element several times on a hard surface to remove excess dirt, or blow compressed air through the filter from the inside. Never try to brush off dirt; brushing will force dirt into the fibers.
4. Reinstall the air filter elements and the cover.

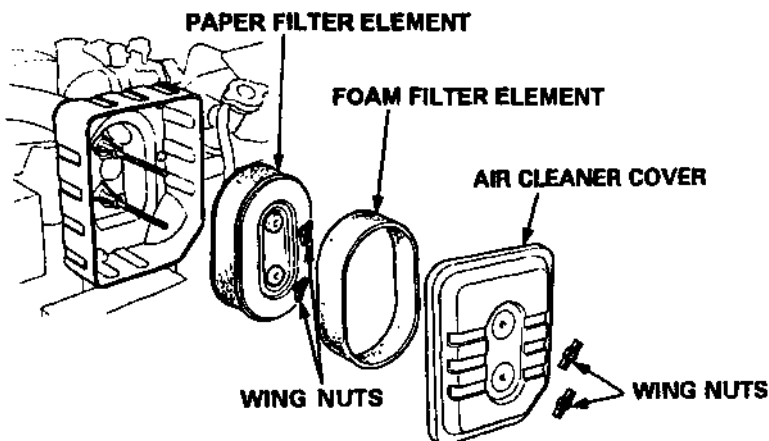

Spark Plug Service

Recommended spark plugs: BPR4HS (NGK)

For good performance, the spark plugs must be properly gapped and free of deposits.

If the engine has been running, the muffler will be very hot. Be careful not to touch the muffler.

1. Disconnect the spark plug caps, and remove any dirt from around the spark plug area.
2. Remove the spark plugs with a spark plug wrench.

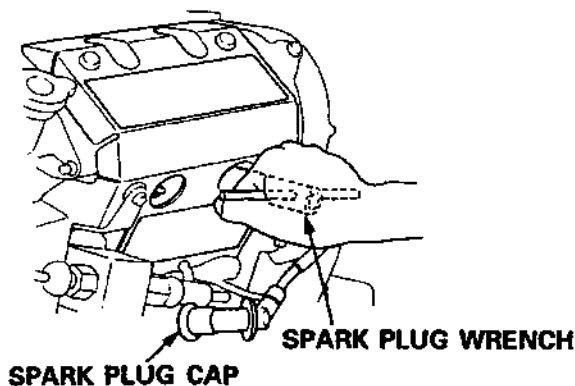

3. Inspect the spark plugs. Replace them if the electrodes are worn, or if the insulators are cracked or chipped. Clean the spark plugs with a wire brush if you will be reusing them.
4. Measure the gap of each spark plug with a feeler gauge. The gap should be 0.6—0.7 mm (0.024—0.028 in). Correct the gap as necessary by carefully bending the side electrode.

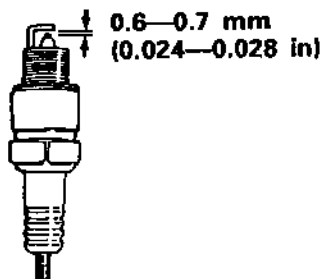

-
5. Install the spark plugs carefully by hand, to avoid cross-threading.

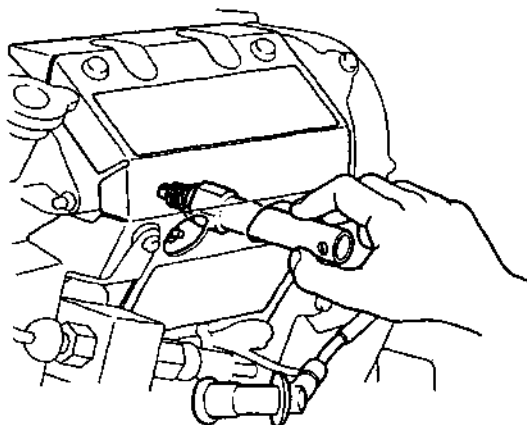

6. After the spark plugs are seated, tighten with a spark plug wrench to compress the washers.

If installing new spark plugs, tighten $1/2$ turn after the spark plugs seat to compress the washers. If reinstalling used spark plugs, tighten $1/8 - 1/4$ turn after the spark plugs seat.

NOTICE The spark plug must be securely tightened. An improperly tightened spark plug can become very hot and could damage the engine. Never use spark plugs which have an improper heat range. Use only the recommended spark plugs or equivalent.

Spark Arrester Maintenance

If the generator has been running, the muffler will be very hot. Allow it to cool before proceeding.

NOTICE The spark arrester must be serviced every 100 hours to maintain its efficiency.

Clean the spark arrester as follows:

1. Remove the cleanout bolt from the spark arrester.
2. Start the engine and run it for several minutes. Exhaust gas will blow loose carbon particles through the hole where the cleanout bolt was removed.

WARNING Exhaust contains poisonous carbon monoxide, which is a colorless and odorless gas that can cause loss of consciousness and may lead to death. Provide enough ventilation to keep exhaust gas from building up.

3. Reinstall the cleanout bolt, and tighten it securely.

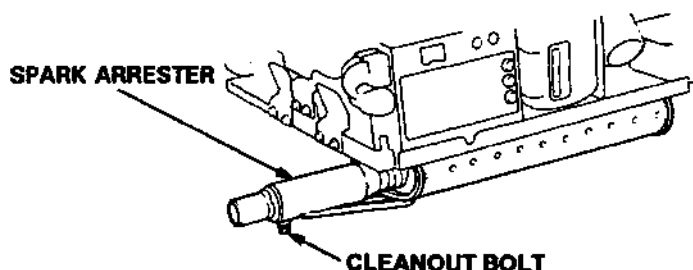

STORAGE

For storage of less than 1 month:

No storage preparation required.

For storage of 1 to 2 months:

1. Fill the vehicle's fuel tank with fresh gasoline, and add a gasoline conditioner that is formulated to extend fuel storage life.
2. Run the generator's engine for 10 minutes to be sure the carburetor float bowl contains treated gasoline.

For storage of 2 months or longer:

1. Change the engine oil (see page 25).
2. Remove the spark plugs, and pour a tablespoon of clean engine oil into each cylinder. Crank the engine for several seconds to distribute the oil, then reinstall the spark plugs.

If the cylinders are coated with oil, the engine will smoke briefly at start-up; this is normal.

3. Drain the carburetor by placing the drain tube in a suitable gasoline container and loosening the drain screw. Retighten the screw after draining.

⚠ WARNING Gasoline is extremely flammable, and gasoline vapor can explode, causing serious injury or death. Use extreme care when handling the gasoline.

Keep flames and sparks away, and do not smoke in the area. Be sure the generator compartment is dry and clear of fuel vapor before starting the engine.

CARBURETOR DRAIN SCREW

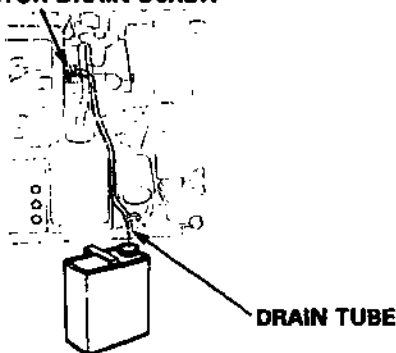

TROUBLESHOOTING

STARTER MOTOR WILL NOT OPERATE

1. Check the vehicle battery and battery connector to the generator.
2. Check the F1 fuse (see page 20).

STARTER MOTOR WORKS, BUT ENGINE WILL NOT START

1. Check fuel level. Some vehicles will not supply fuel to the generator when the fuel tank level is below a certain limit.
2. Turn off all electrical loads (lights and appliances), or turn the circuit breaker(s) OFF. Turn the circuit breaker(s) ON after the engine starts.
3. Check the F2 fuse (see page 20).
4. Check the spark plugs (see page 27). Be sure the spark plugs are clean and properly gapped. If the engine still does not start, install new spark plugs and try again.

ENGINE STARTS, BUT STOPS IMMEDIATELY

1. The engine protection system may have been activated (see page 19). If the temperature warning lamp is lit, check the coolant level; if not, check the engine oil level.
2. Check the F3 fuse (see page 20).

ENGINE RUNS, BUT THERE IS NO ELECTRICITY OUTPUT

1. Check that the generator circuit breaker is in the ON position.
2. If the vehicle is equipped to isolate the generator when using an outside power source, check to be sure the generator has been reconnected.
3. Check circuit breakers and ground fault circuit interrupters in the vehicle. If they have been tripped (switched off), check appliances or equipment for malfunction before further use.

WIRING DIAGRAMS

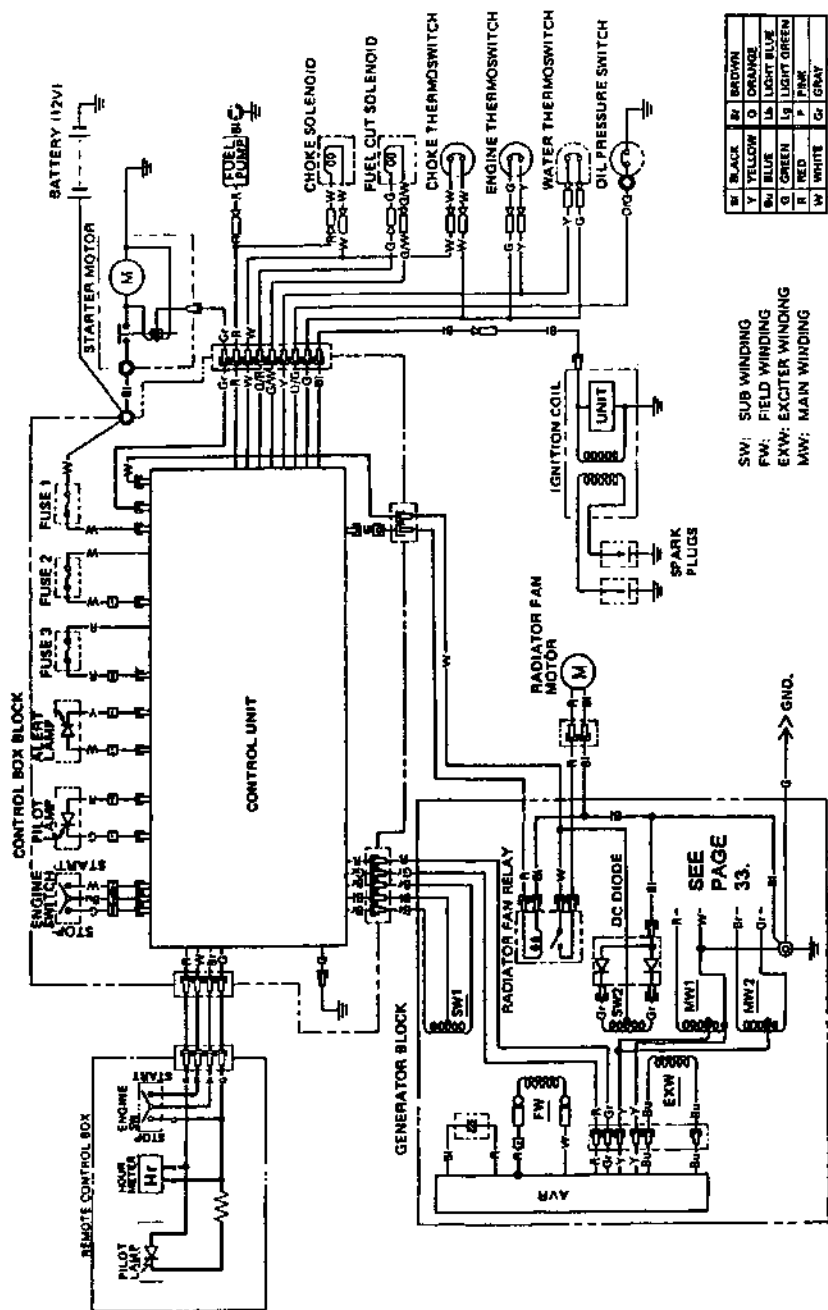

B	BLACK	Br	BROWN
Y	YELLOW	O	ORANGE
Bu	BLUE	Ls	LIGHT BLUE
G	GREEN	Lg	LIGHT GREEN
R	RED	P	PINK
W	WHITE	Gr	GRAY

SW: SUB WINDING
 FW: FIELD WINDING
 EXW: EXCITER WINDING
 MW: MAIN WINDING

SEE PAGE 33.

Single 120-Volt and Dual 120/240-Volt Wiring Connections

Single 120-Volt ac Output

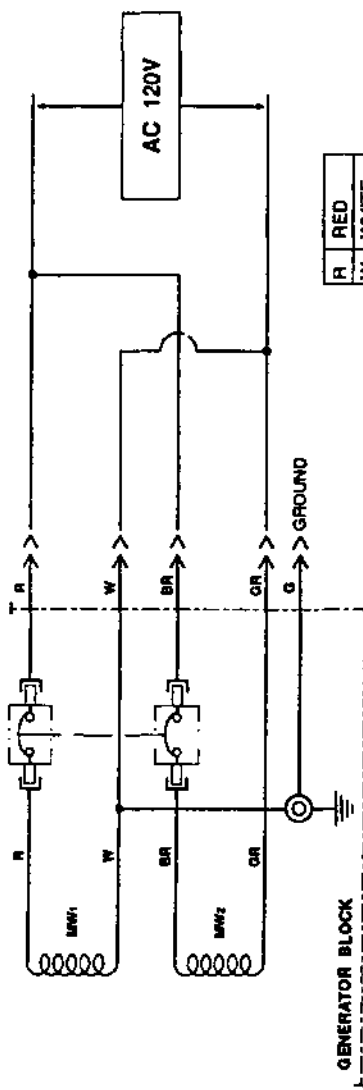

R	RED
W	WHITE
BR	BROWN
GR	GRAY
G	GREEN

Dual 120/240-Volt ac Output

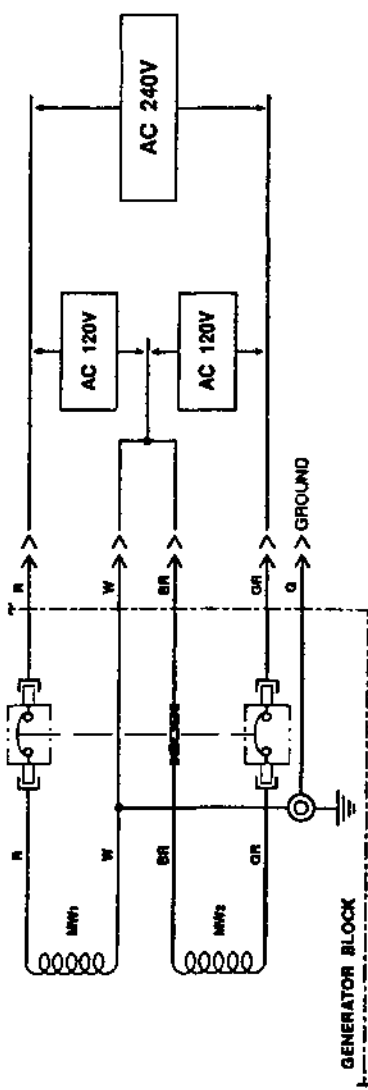

SPECIFICATIONS

Dimensions

Model	EVD6010
Length x Width x Height (without muffler and spark arrester)	650 x 485 x 360 mm (25.6 x 19.1 x 14.2 in)
Dry weight	97 kg (214 lb)

Engine

Model	GX360K1
Engine type	4-stroke, OHC Twin cylinder
Displacement (Bore x Stroke)	359 cc (21.9 cu in) [58 x 68 mm (2.3 x 2.7 in)]
Compression ratio	8.5 : 1
Standard speed	3,750 \pm ⁺³⁰ ₀ rpm
Cooling system	Liquid cooled
Ignition system	Transistorized magneto
Oil capacity	1.2 ℓ (1.27 US qt, 1.06 Imp qt)
Spark plug	BPR4HS (NGK)

Generator

Type	2-pole, revolving magnetic field	
AC output	Rated voltage	120/240 V
	Rated frequency	60 Hz
	Rated ampere	50/25 A
	Rated output	6.0 kVA
	Maximum output	6.0 kVA

Specifications are subject to change without notice.

WARRANTY SERVICE INFORMATION

Serviceing dealership personnel are trained professionals. They should be able to answer any question you may have. If you encounter a problem that your dealer does not solve to your satisfaction, please discuss it with the dealership's management. The Service Manager or General Manager can help. Almost all problems are solved in this way.

If you are dissatisfied with the decision made by the dealership's management, contact the dealership's Honda RV generator distributor. You can obtain the distributor's address and phone number by writing or calling the Honda Power Equipment Customer Relations Office.

**American Honda Motor Co., Inc.
Power Equipment Division
Customer Relations Office
4475 River Green Parkway
Duluth, Georgia 30136-2565**

Or telephone: (770) 497-6400

When you write or call the Honda Power Equipment Customer Relations Office, or the Honda RV generator distributor, please provide the following information:

- Model and serial numbers (see page 9)
- Name of the dealer who sold the generator to you
- Name and address of the dealer who services your generator
- Date of purchase
- Your name, address, and telephone number
- A detailed description of the problem

INDEX

COMPONENT IDENTIFICATION	9
Control Box	10
CONTENTS	2
GENERATOR INSTALLATION AND CONNECTIONS	7
Connection for a Vehicle	7
Connection to a Building's Electrical System	8
GENERATOR USE	18
Appliance Operation	18
Circuit Breakers and Fuses	20
Engine Protection System	19
High Altitude Operation	21
MAINTENANCE	22
Air Cleaner Service	26
Engine Oil Change	25
Maintenance Record	24
Maintenance Schedule	23
Spark Arrester Service	29
Spark Plug Service	27
Tool Kit	22
PRE-OPERATION CHECK	11
Coolant	14
Engine Oil	11
Exhaust System	16
Fuel	12
SAFETY	4
Safety Information	5
Safety Label Locations	4
SPECIFICATIONS	34
STARTING AND STOPPING THE ENGINE	17
Starting the Engine	17
Stopping the Engine	17
STORAGE	30
TROUBLESHOOTING	31
WARRANTY SERVICE INFORMATION	35
WIRING DIAGRAMS	32

HONDA

HONDA MOTOR CO.,LTD. TOKYO, JAPAN

31ZB5800

0259905